

Copyright. All information furnished within this document, electronic file or design correspondence is the property of Den Hartog industries, Inc. and shall not be used, disclosed to others or copied without the expressed written consent of Den Hartog Industries, Inc.

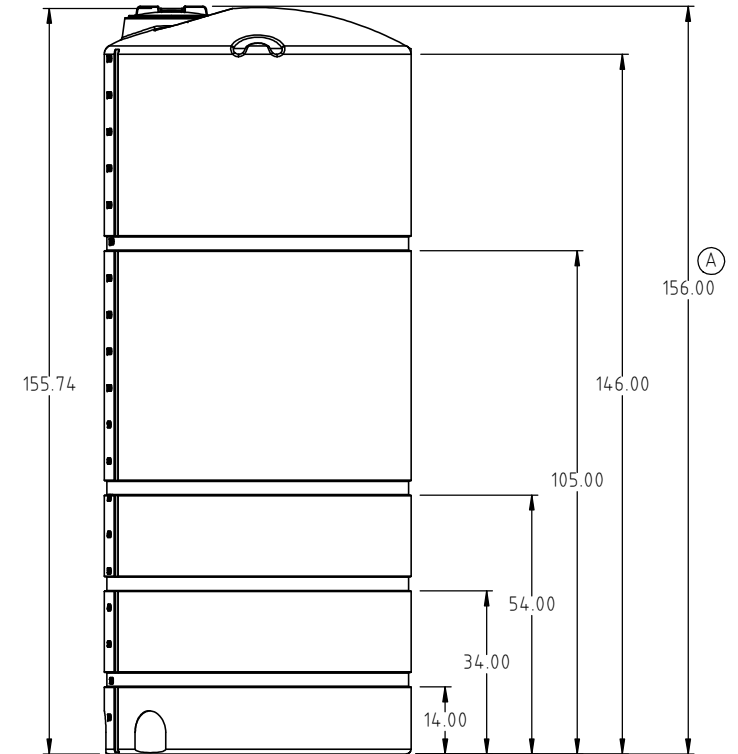

				DRAWN / DATE DHJ 5/8/98	MATERIAL HDPE OR EQUIVALENT REFERENCE MATERIAL DATA SHEET FOR SPECIFIC PROPERTIES.
B	SHOT WEIGHT CHANGED TO MATCH B.O.M. DRAWING TEMPLATE UPDATED	ADH 11/2/11	2322	APPRD. / DATE REH 5/8/98	
A	156.00 WAS 157.00	2/15/07			
REV	DESCRIPTION	BY / DATE	CCN		
ALL DIMENSIONS ARE IN DECIMAL INCHES TOLERANCES UNLESS OTHERWISE SPECIFIED		THIRD ANGLE PROJECTION ANSI 14.5M		SHOT WEIGHT: 465.00 LBS	NOTES: 1.) 2.7 % SHRINK ALLOWANCE 2.) BLUE, GREEN, BLACK, WHITE, OR YELLOW COLOR
POLYETHYLENE		METAL DECIMAL ± .125" FRACTION ± 1/4" ANGLE ± 1°		SHIPPING WEIGHT: 467.00 LBS	
±1% @ 68°F				FINISH:	

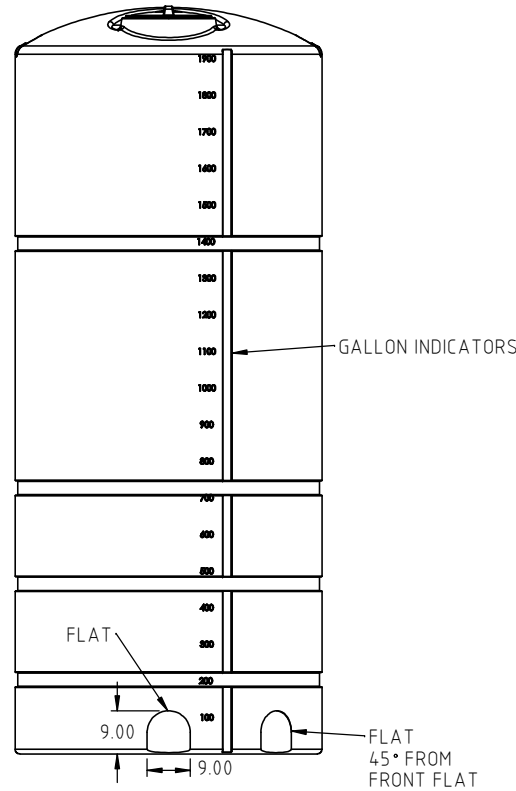
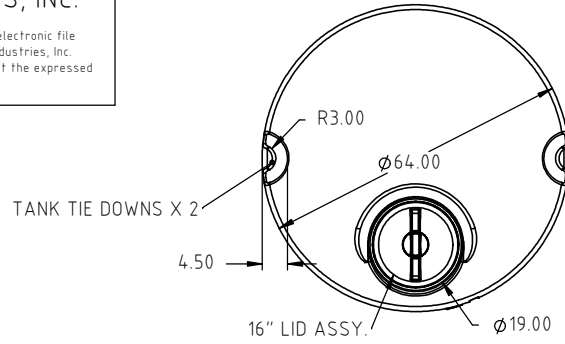

Den Hartog
INDUSTRIES, INC.

Acro Roto-Mold Injection Molding Blow Molding Sowjoy

4010 HOSPERS DRIVE S. BOX 425, HOSPERS, IOWA 51238-0425

DESCRIPTION	2000 GALLON VERTICAL TANK	
SCALE	N.S.	PART NO. VT2000-64